

REVERSIBLE FAN - SEQUENCE OF OPERATION

REVERSIBLE FAN PROVIDES PERIODIC FRESH AIR & EXHAUST VENTILATION FOR BATHROOM(S) WITH THE FOLLOWING SEQUENCE OF OPERATION:

SUPPLY AIR MODE - SUPPLY FAN RECEIVES A SIGNAL FROM WALL MOUNTED THERMOSTAT TO PROVIDE FRESH AIR TO THE BATHROOM/FAN COIL UNIT.

EXHAUST AIR MODE- EXHAUST FAN RECEIVES A SIGNAL FROM WALL MOUNTED EXHAUST/CONDENSATION (HUMIDITY) CONTROLLER TO EXHAUST AIR FROM THE BATHROOM.

WHEN THE REVERSIBLE FAN IS ON SUPPLY AIR MODE, AND EXHAUST AIR IS REQUIRED BY EXHAUST CONTROLLER, IT SWITCHES TO THE EXHAUST MODE.

- 1 EXHAUST CONNECTIONS
- 2 VENTILATION CONNECTIONS
- 3 LOW VOLTAGE POWER (24VAC) FROM THERMOSTAT.

- HIGH VOLTAGE (120V-1Ø-60Hz)
- - - LOW VOLTAGE (24VAC)
- FCU FAN COIL UNIT
- XFMR TRANSFORMER
- (M) BY MECHANICAL
- (E) BY ELECTRICAL
- CB DEDICATED CIRCUIT BREAKER IN ELECTRICAL PANEL

SK-1
Date: 03-22-17

REVERSIBLE FAN WITH THERMOSTAT WIRING DIAGRAM

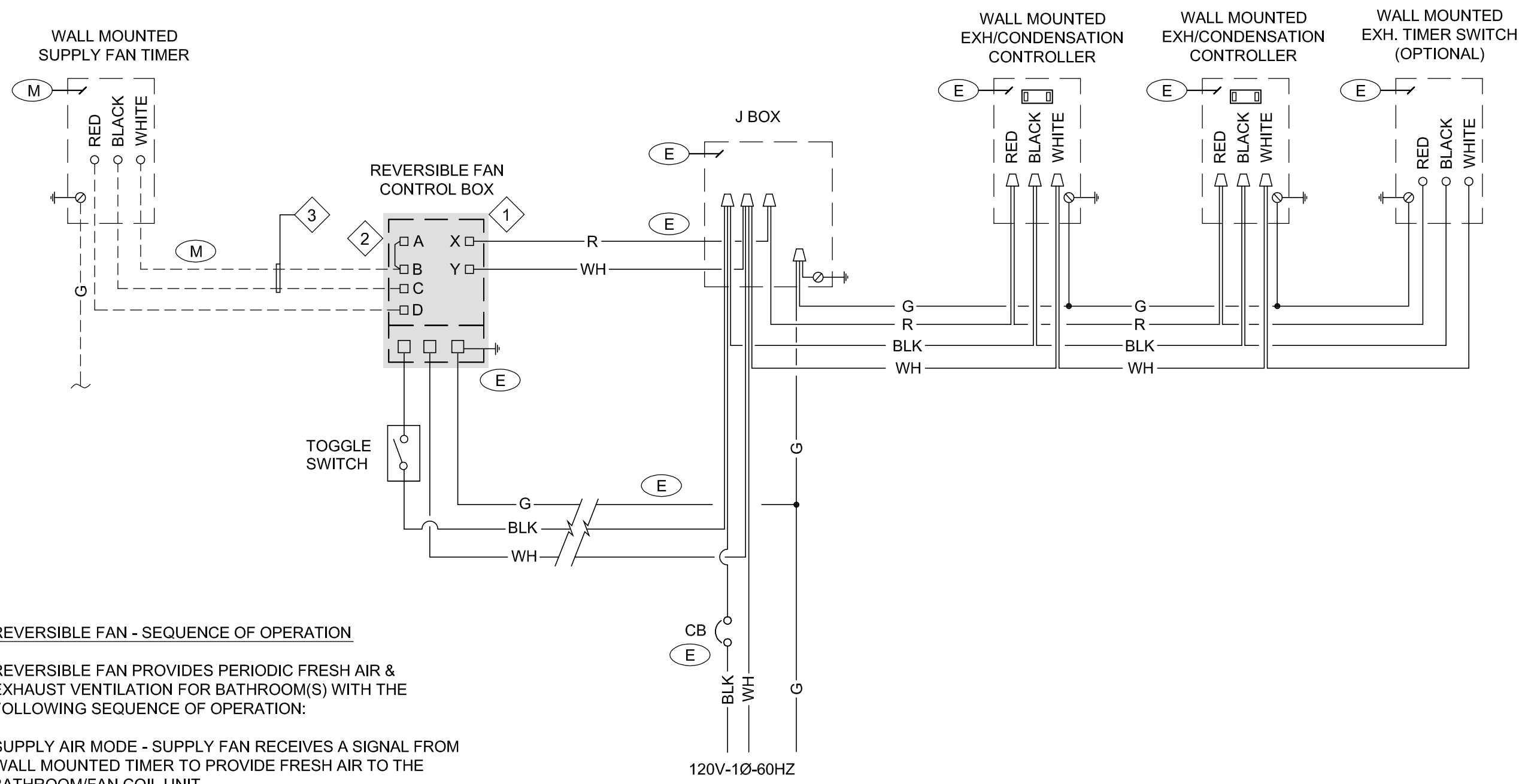

REVERSIBLE FAN - SEQUENCE OF OPERATION

REVERSIBLE FAN PROVIDES PERIODIC FRESH AIR & EXHAUST VENTILATION FOR BATHROOM(S) WITH THE FOLLOWING SEQUENCE OF OPERATION:

SUPPLY AIR MODE - SUPPLY FAN RECEIVES A SIGNAL FROM WALL MOUNTED TIMER TO PROVIDE FRESH AIR TO THE BATHROOM/FAN COIL UNIT.

EXHAUST AIR MODE- EXHAUST FAN RECEIVES A SIGNAL FROM WALL MOUNTED EXHAUST/CONDENSATION (HUMIDITY) CONTROLLER TO EXHAUST AIR FROM THE BATHROOM.

WHEN THE REVERSIBLE FAN IS ON SUPPLY AIR MODE, AND EXHAUST AIR IS REQUIRED BY EXHAUST CONTROLLER, IT SWITCHES TO THE EXHAUST MODE.

- 1 EXHAUST CONNECTIONS
- 2 VENTILATION CONNECTIONS
- 3 LOW VOLTAGE POWER (24VAC) FROM REVERSIBLE FAN.

- HIGH VOLTAGE (120V-1Ø-60Hz)
- - - LOW VOLTAGE (24VAC)
- FCU FAN COIL UNIT
- XFMR TRANSFORMER
- (M) BY MECHANICAL
- (E) BY ELECTRICAL
- CB DEDICATED CIRCUIT BREAKER IN ELECTRICAL PANEL

SK-2
Date: 03-22-17

REVERSIBLE FAN WITH TIMER WIRING DIAGRAM